

Operation & Installation Guide

MHCB3035D40D50308

Honeywell

Model / Modèle / Modelo / Modell:
3035D / 3035DE / 3035DBJ / 3040D / 3040DE / 3040DBJ

DELUXE SECURITY BOX with Digital Electronic Lock

Read These Instructions Very Carefully!
Lire ces instructions très attentivement!
¡Sírvase leer estas instrucciones cuidadosamente!
Bitte lesen Sie diese Anleitung genau durch!
Lees deze instructies zorgvuldig door!



English
Français
Español
Deutsch
Nederlands



Fig. 1

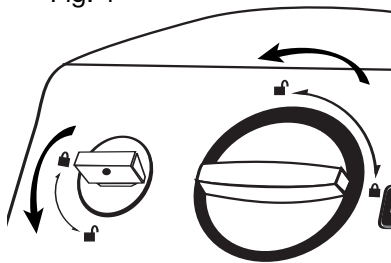

Fig. 2

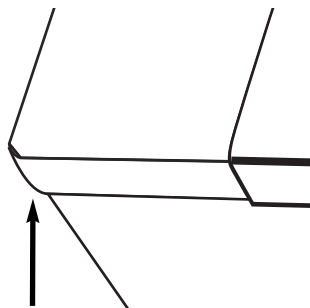

Fig. 3

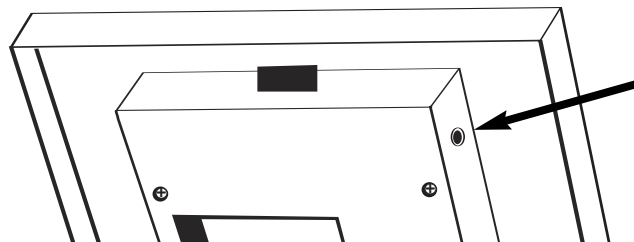

Fig. 4

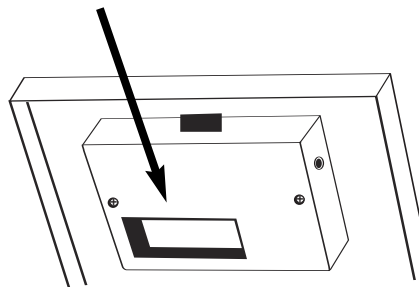

Fig. 5

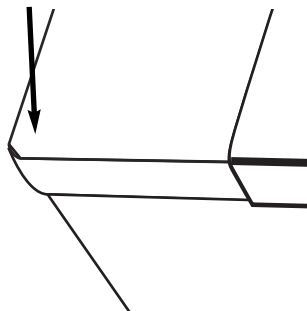
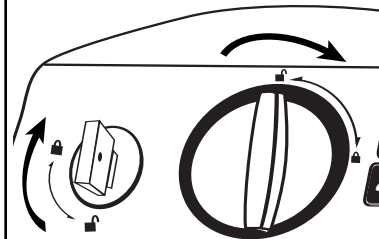

Fig. 6



Important

Welcome to the HONEYWELL Family of Products

Along with peace of mind, your Honeywell Digital Security Box will provide many years of secure storage for your valuables.

For security, you should:

- ▶ Immediately set your own personal combination.
- ▶ Store the keys and personal combination away from the security box.
- ▶ Mail the warranty registration card or register via the internet at www.HoneywellSafes.com

The pre-set factory code for your safe is:

3 *

Overview

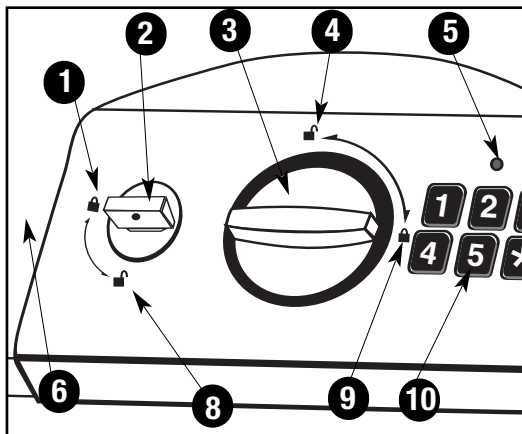

1. Locked override key icon
2. Override key lock
3. Rotating knob or latching handle
4. Unlocked knob icon
5. LED Indicator light
6. Security box lid
7. Red code setting button
(see diagram to the right)
8. Unlocked override key icon
9. Locked knob icon
10. Digital keypad buttons
11. Security cable attachment hole plug

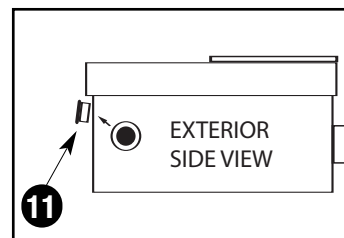
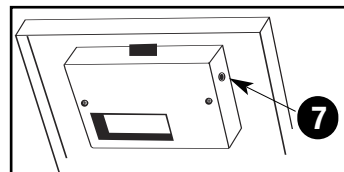

Your Security Box Includes

- (4) "AA" Batteries
- (1) Foam pad providing added protection for your valuables
- (2) Override keys
- (1) Key lock cover
- (1) 4 foot steel secure cable (3040D, 3040DE, 3040DBJ)
- (1) Security cable attachment hole plug (3040D, 3040DE, 3040DBJ)

Getting Started

STEP 1: Locate Override Keys

Keys and batteries are stored in the packing material. Remove them before discarding the box.

STEP 2: Opening your Security Box using your override key

- ▶ Remove cover from key lock.
- ▶ Insert Override Key into key lock and turn the key counter clockwise one quarter turn to the unlocked position.
- ▶ Turn the knob counter-clockwise one quarter turn to the unlocked position. (fig.1)
- ▶ To open, lift from the outer edge of the lid. (fig.2)

STEP 3: Installing Batteries

- ▶ Locate the battery cover on the back side of the lid. (fig.4)
- ▶ Slide the cover off the battery compartment.
- ▶ Properly insert batteries, noting correct direction, replace cover and close the Security Box lid.
- ▶ Return the Override Key and the knob to the locked position.

STEP 4: Opening your Security Box using the pre-set factory code

THE PRE-SET FACTORY CODE IS 3 *

- ▶ Using the keypad, enter the factory pre-set code. The LED will flash a green light and stay green for 10 seconds after the * button is pressed. You will hear the Security Box unlock.

NOTE: You have 10 seconds to open the Security Box. If the green light goes out, you will have to re-enter the code.

- ▶ To open, turn the knob from the locked position to the unlocked position, one quarter turn counter-clockwise. To open, lift from the outer edge of the lid. (fig.2)
- ▶ If the LED light flashes red after you enter the code, this means the code was entered incorrectly and the Security Box will not open.

NOTE: If an incorrect code is entered 3 times in a row, the Security Box will automatically shut down for 4 minutes before it can be opened again using the correct code. During this delay, the Override Key can be used to open the Security Box.

Programming your Personal Code

NOTE: For your security, immediately re-program the digital lock to your Personal Passcode.

Open your Security Box with the Override Key or with the pre-set factory Passcode.

- ▶ On the inside of the lid, find and press the red button located to the side of the battery compartment (Fig.3). The LED light above the keypad will flash orange.
- ▶ Enter your personal Passcode, up to 5 digits, followed by the * button and then repeat a second time. You must enter the number twice.
- ▶ For example: 1 2 3 4 5 * - 1 2 3 4 5 *
After the first entry, the LED will flash orange. After the second entry, the LED will flash green and then go out.
- ▶ Your Personal Passcode is now saved. Write it down and store it in a secure place away from the Security Box.
- ▶ Close the lid of your Security Box and return the knob to the locked position (Fig. 6). If the override key was used, turn to the locked position, remove and replace the lock cover.

NOTE: The factory pre-set code is no longer active and cannot be used to open the Security Box.

Closing and Securing your Security Box

Be careful not to overfill your Security Box or obstruct the door from completely closing.

- ▶ Make sure knob is in the unlocked position.
- ▶ Make sure lid is closed completely. (Fig. 5)
- ▶ Turn the knob from the unlocked position one quarter turn clockwise to the locked position. Your Security Box should now be secured.

NOTE: While the override key is in the unlocked position you can open and close the Security Box by turning the knob from the locked to the unlocked position and back again without entering your personal code. To secure your Security Box, make sure that you have turned the override key to the locked position and have stored the key away from the Security Box in a safe place.

Troubleshooting

- ▶ **No light from LED:** This indicates that the batteries are expired and need to be replaced. To change the batteries, see Getting Started STEPS 2 & 3.

NOTE: Replacing batteries does not erase your personal code.

- ▶ **The LED is blinking a red light:** This means that your batteries are low. To change your batteries, see Getting Started STEPS 2 & 3.

- ▶ **Warning: DO NOT FORCE THE KNOB**
If forced, the knob will break and your Security Box will be damaged. When operated correctly, the knob will function so that it can be turned easily into the opened position.

If you have additional questions while operating your Security Box, please call SISCO Customer Service at 1-800-223-8566. Please call our Customer Service line prior to returning your Security Box to the retailer.

Security Cable

Models 3040D, 3040DE, and 3040DBJ include security cable.

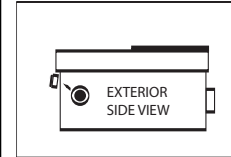

- 1 Remove the plug from security cable attachment hole.

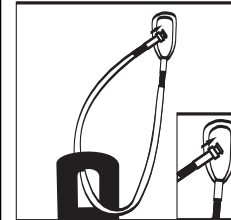

- 2 Loop cable around desired object and then through itself.

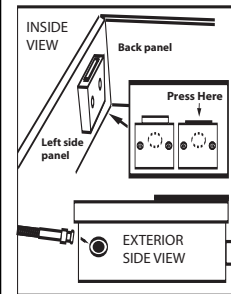

- 3 Depress cable release button and while holding down, insert security cable into the hole as shown in diagram, then release button.

Customer Support

How to Contact Us

Phone: 1-800-223-8566

Monday through Friday, 7:30 am to 4:30 pm

Pacific Standard Time

Email: CustomerService@HoneywellSafes.com

In addition to the required information regarding your Security Box, you must include the best time and proper telephone number to reach you during our normal Customer Service hours. You should receive a reply response via e-mail or phone within 24 business hours or the following business day.

Mail:

Attn: Customer Service Dept.

SISCO

2835 E. Ana Street

Rancho Dominguez, CA 90221

Internet: www.HoneywellSafes.com

Replacement Keys

Ordering Replacement Keys:

If a key becomes misplaced or you would like additional keys for your Security Box, you may conveniently purchase them from our Customer Service Department.

Payment and Delivery:

In the US, replacement keys are available for a fee and credit card orders are accepted by telephone and through our website. Checks or money orders are required for orders received by mail and should be made payable to "SISCO".

You must supply the following information to assure accurate and prompt processing:

- Name / Address / Telephone
- Security box Model Number
- E-mail address (if available)
- Number of keys requested
- Key number (located on the lock)

Terms subject to change without notice

Appropriate Use of Your Security Box

Your steel Security Box is designed to provide minimal security against theft and is insulated with fire retardant material. For safes that provide maximum protection from fire or water damage, see your Security retailer, or visit our HONEYWELL web site: www.HoneywellSafes.com

Limited warranty

SISCO warrants its Steel Boxes to be free of defects in material and workmanship for a period of 90 days from the date of purchase. If your Steel Box should fail to work during the first 90 days due to any factory defects, it will be repaired or replaced free of charge. Return the defective Steel Box in its original carton, freight prepaid, using a traceable method along with an explanation of the problem to the address listed below. Upon examination, the unit will either be repaired or replaced and shipped back to you prepaid. This warranty is void if the item has been misused in any way. This warranty only applies to the original purchaser. Please allow 2-4 weeks for the reshipment to arrive.

SISCO
2835 E. Ana Street
Rancho Dominguez, CA 90221

Honeywell makes no representations or warranties with respect to this product or service. The Honeywell Trademark is used under license from Honeywell Intellectual Properties Inc. by SISCO.

Home and Office Security Safes
Coffres-forts résidentiels et commerciaux
Cajas fuertes de seguridad para la oficina y el hogar
Sicherheitssafes für Heim und Büro
Brandkasten voor thuis en kantoor



US/Canada - Etats-Unis/ Canada - EUA/Canadá - USA/Kanada - V.S./Canada
2835 East Ana Street Rancho Dominguez, CA 90221-5601 USA

US/Canada Toll Free:
Numéro sans frais aux Etats-Unis/ Canada:
EUA/Canadá llamada telefónica gratis:
USA/Kanada gebührenfrei:
V.S./Canada gratis nummer:
800-223-8566

US/Canada - EUA/Canadá - Etats-Unis/ Canada:
310-638-1182
Fax - Facsímile:
310-638-6489
Email - Courriel:
CustomerService@HoneywellSafes.com

www.HoneywellSafes.com

Europe - Europa
c/o - Atención - p/a:
Freightways Distriservices B.V.
P.O. Box 3077
2220 CB Katwij
The Netherlands
+31 71 4090721

Australia-l'Australie-Austrelien-Australië
c/o - Atención - p/a:
Customer Service Dept.
Master Distributors
11 Howleys Road
Notting Hill VIC 3168
03-9538-9200

Honeywell